



***motoalliance***



**FIRESTORM**

C A B H E A T E R S

**Polaris Ranger 570 Cab Heater**

**HT\_CU\_404-570**

INSTALLATION INSTRUCTIONS

**PARTS LIST**

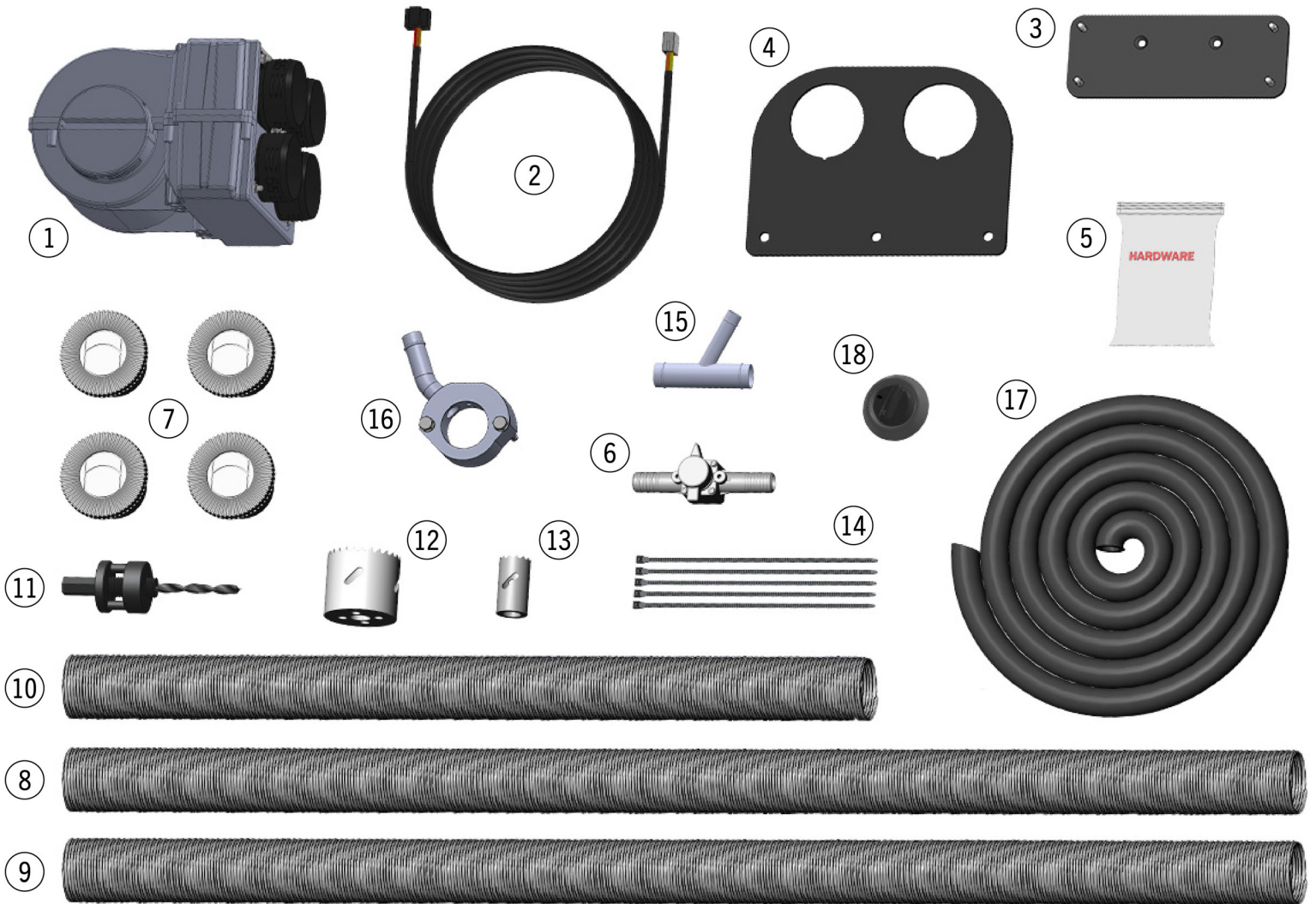

Part#	Qty	Item Description
1	1	FIRESTORM Cab Heater Unit
2	1	36" Wiring Harness
		Orange/Yellow/Black Wire
		Red Wire
		Black Wire
		5-Pin Black Connector
		4-Pin White Connector
3	1	HT_CU_499-4 Heater Mount Bracket
4	1	HT_CU_499-3 Vent Mount Bracket
5	1	Hardware Pack

Part#	Qty	Item Description
2	2	Rubber Grommet
2	2	M6-1.0x12mm Flat Head Cap Screw
3	1	1/4"-20x3/4" Serrated Flange Bolt
7	4	1/4"-20 Serrated Flange Nut
2	2	Insulation Displacement Crimp
6	1	#10 Stainless Steel Hose Clamps
2	2	#16 Stainless Steel Hose Clamps
6	1	Plastic Shut-Off Valve
7	4	2" Vent
8	15"	2" Compressed Duct Hose

Part#	Qty	Item Description
9	15"	2" Compressed Duct Hose
10	10"	2" Compressed Duct Hose
11	1	Hole Saw Pilot Bit
12	1	2" Hole Saw
13	1	1 1/4" Hole Saw
14	20	Zip Ties
15	1	1" Aluminum Y
16	1	Thermostat Bypass Valve BP104
17	20'	5/8" Coolant Hose
18	1	3-Position Switch



Please read all instructions before beginning installation. Verify that all parts listed are present.

We have found that several steps in this installation are easier with two people. We recommend finding a partner to assist with this installation.



When working on cooling systems, always allow vehicles to cool to avoid being burned or scalded by hot coolant.

Before working with any electrical system on your vehicle, **ALWAYS** remove the negative battery cable and secure it away from the battery terminal.

## PREPARATION

1. Disconnect the negative battery terminal from the battery and secure away.
2. Loosen the top dash by extracting the four plastic retaining clips. **FIGURE 1**



**FIGURE 1**

3. Remove the radiator hood by twisting the two retaining knobs; set the radiator hood aside.
4. Remove the center drive shaft tunnel cover by extracting the four plastic retaining clips as shown in **FIGURE 2**. Set the tunnel cover aside.



**FIGURE 2**

5. Remove the plastic underbody panels to allow easier radiator hose routing in later steps.

### DEFROST ASSEMBLY

Check behind where the vents will go to ensure that no damage will occur when drilling holes.

6. Cut out and attach the driver side defrost vent template (template #2) and passenger side defrost vent template (template #3) as shown in *FIGURE 3*.

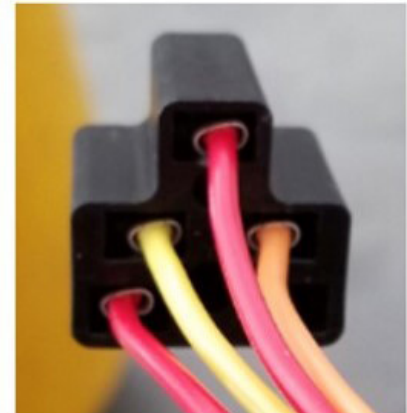
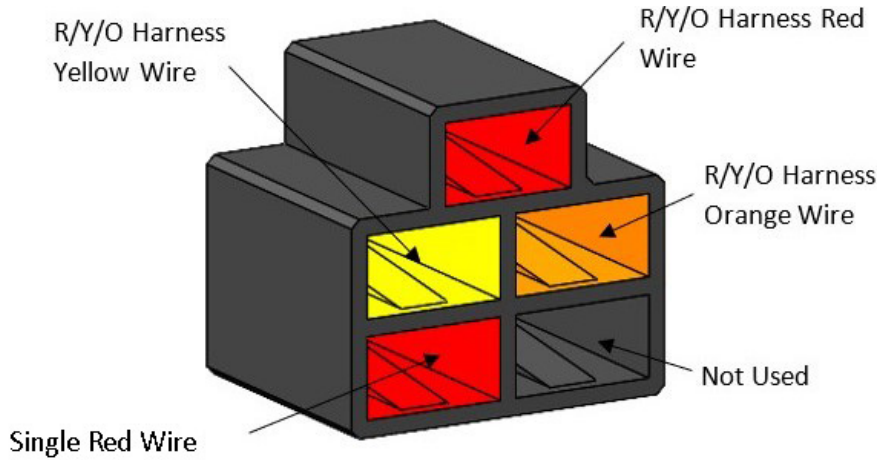

**FIGURE 3**

7. Mark the hole centers as shown in template #2 and template #3 and drill a 2" hole using the included 2" hole saw and pilot bit. Clean any burs from around the hole with a debur tool or knife.
8. Insert two of the 2" vents into the holes until they click firmly into place.
9. Remove the top dash to gain access to the backside of it.
10. Attach one 15" section of 2" duct hose to the driver side defrost vent and secure using zip ties.
11. Attach the 10" section of 2" duct hose to the passenger side defrost vent and secure using zip ties.
12. Set the dash and duct hoses to the side.

**SWITCH WIRING**

13. Locate the 36" Wiring Harness and ensure the wires are correctly connected to the 5-Pin Black Connector as shown in *FIGURE 4* and the 4-Pin White Connector as shown in *FIGURE 5*.



*FIGURE 4*

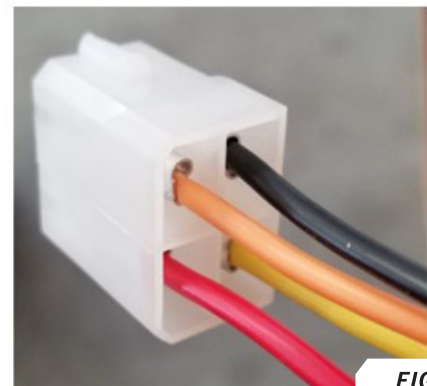
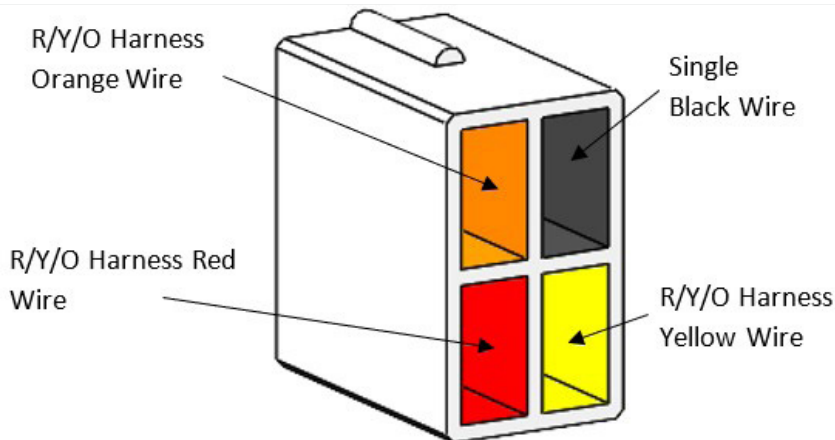

*FIGURE 5*

14. Connect the 5-Pin Black Connector to the 3-Position Switch included in the kit.

15. Position the switch bezel to the right side of the center console as shown in *FIGURE 6*. Note: Position the switch bezel as close to the indicated plastic edge (*FIGURE 6*) as possible to eliminate any chance of the switch housing interfering with the glove compartment reinforcement behind the dash.

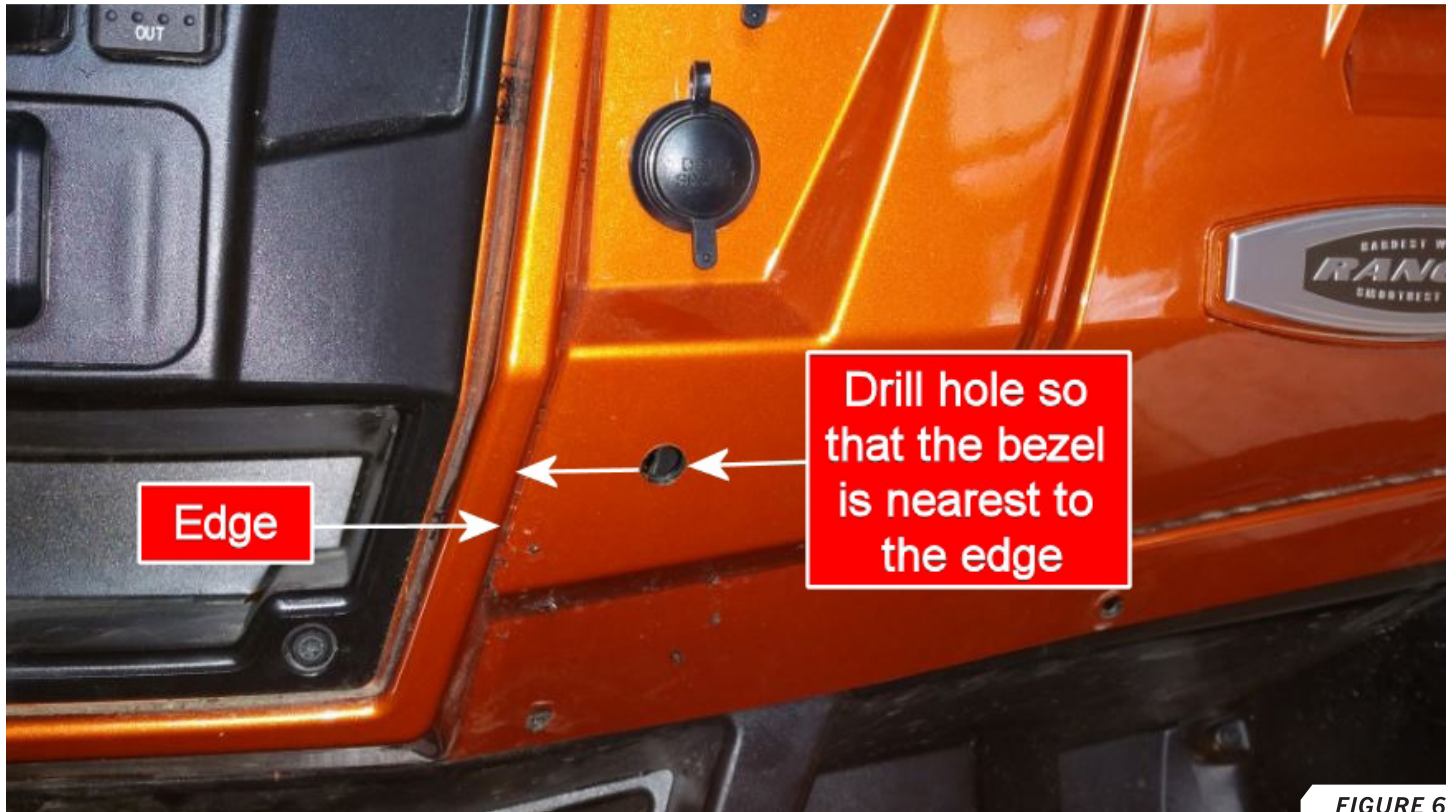

**FIGURE 6**

16. Once positioned in a desirable location, mark the hole center and drill a  $\frac{7}{16}$ " hole.
17. Insert the switch into the  $\frac{7}{16}$ " hole from the back of the center dash panel and secure using the low-profile hex nut included in the switch bag. Disregard the flex lock washer.
18. Prior to pressing the switch bezel on, use a pair of pliers to remove the two nubs on the back of the switch bezel as shown in *FIGURE 7*.
19. Place the bezel over the switch so that the 0, 1, 2, 3 markings are visible. Press the switch dial onto the switch until it is seated firmly.
20. Connect the red wire to a keyed powered source (any power source that is only powered when the vehicle is on) using the terminated end. If you have no connection spot for the terminated end, cut the ring terminal off and use the insulation displacement crimps to connect the red wire to a keyed power source. This can be found by testing wires with a multimeter.



**FIGURE 7**

Common examples may include the ignition, radios, and winches, though this may vary with your vehicle.

21. Attach the single black wire to any ground on your vehicle.

## COOLANT HOSE ROUTING

Before drilling through the firewall, verify there are no wires behind the cutout area.

22. Cut out the heater mounting template (template #1) and attach it to the passenger side firewall following the orientation markings on the template. *FIGURE 8*



*FIGURE 8*

23. Drill the four smaller holes at the designated points on the template using a  $\frac{5}{16}$ " drill bit.
24. Use the  $1\frac{1}{4}$ " hole saw to drill the larger single hole shown in the template. Clean any burrs from around the hole with a debur tool or knife.

25. Install a rubber grommet into the 1¼" hole.
26. Cut out the center tunnel coolant hose template (template #4) and attach it to the firewall at the center of the vehicle and above the drive shaft tunnel.
27. Using the 1¼" hole daw drill through the firewall as shown in *FIGURE 9*. Clean any burrs from around the hole with a debur tool or knife.

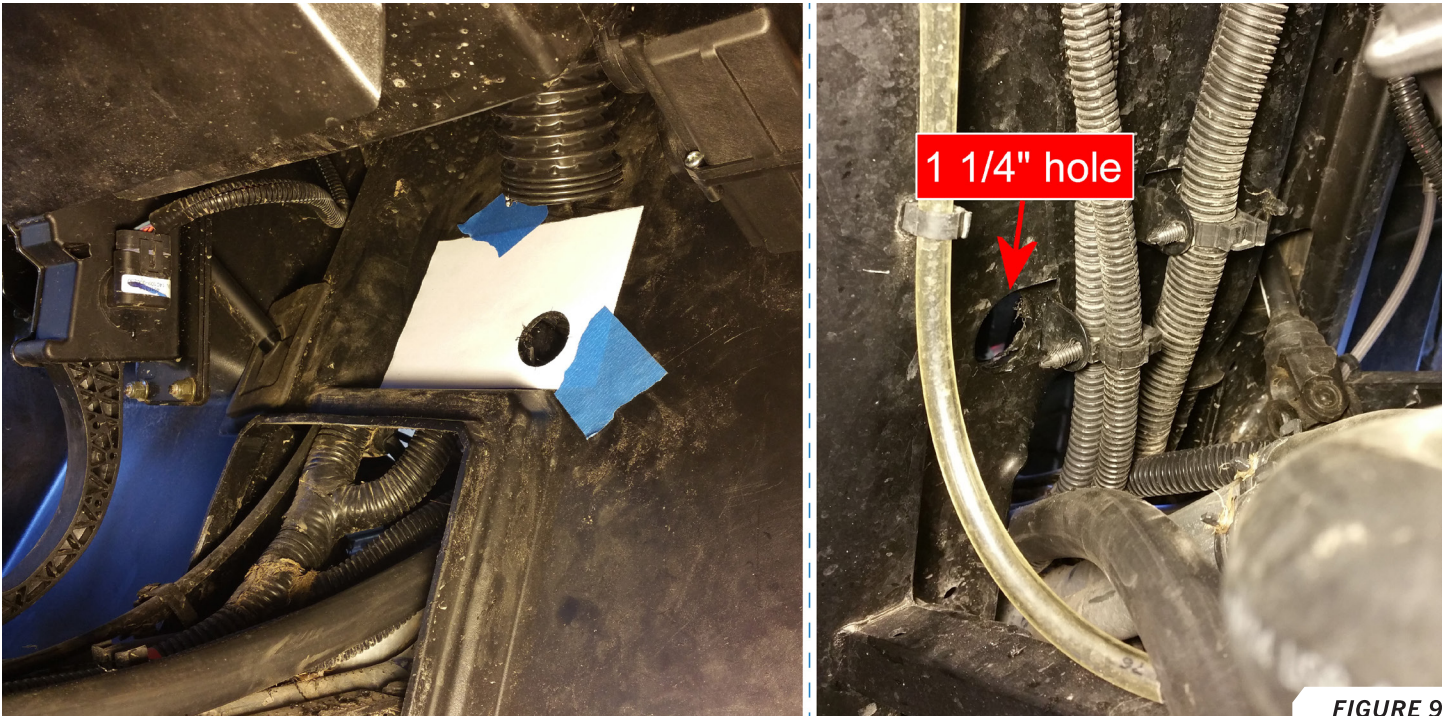

**FIGURE 9**

28. Install a rubber grommet into the 1¼" hole.
29. From the radiator side, push the 34" of 5/8" radiator hose through the center tunnel rubber grommet and route the 5/8" radiator hose toward the passenger footwell.
30. Route the remaining 5/8" radiator hose through the drive shaft tunnel (follow the aluminum coolant lines) toward the passenger side of the engine.
31. Route the 5/8" radiator hose up to the thermostat housing from the passenger side of the engine. The thermostat housing is located on the engine block just below the two black intake manifolds. Cut the 5/8" radiator hose so that it reaches the thermostat housing with an extra 6–12" of hose for any future adjustments.

◀ There should be at least 3' of extra hose that will be used for the heater outlet.



32. Cut the  $\frac{5}{8}$ " radiator hose as shown in *FIGURE 10* and insert the  $\frac{5}{8}$ " plastic shutoff valve into the opening with the knob facing upward.

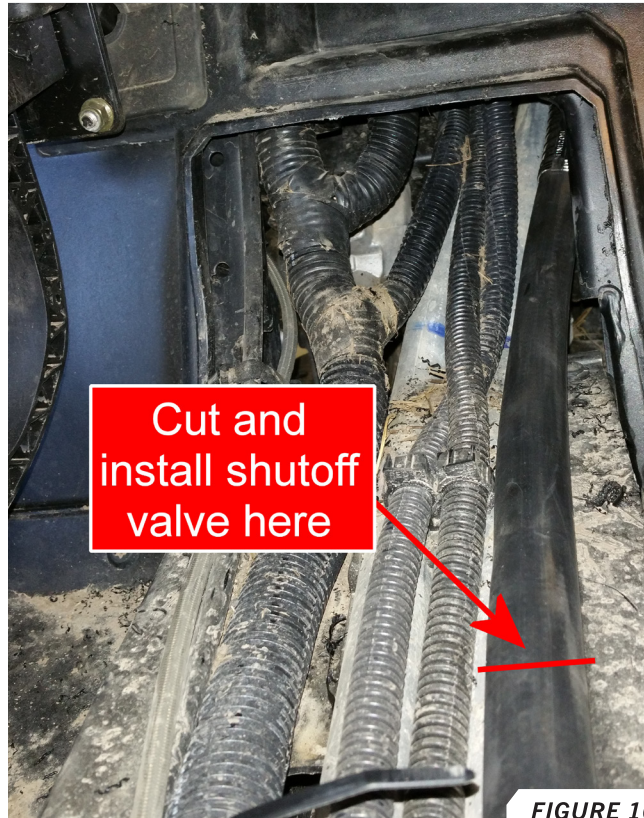

33. Secure with two #10 hose clamps.
34. Reinstall the drive shaft tunnel cover as shown in *FIGURE 11*.



35. Push the long end of the  $\frac{5}{8}$ " radiator hose through the remaining rubber grommet from the cab side of the firewall. Leave the hose unattached for now.

### IN-CAB VENT INSTALLATION

36. Insert the two remaining 2" vents into the vent bracket until they click.
37. Hold the vent bracket up to lower portion of the dash leaving roughly a 1" overlap from the top of the bracket to the bottom edge of the plastic as shown in *FIGURE 12*.

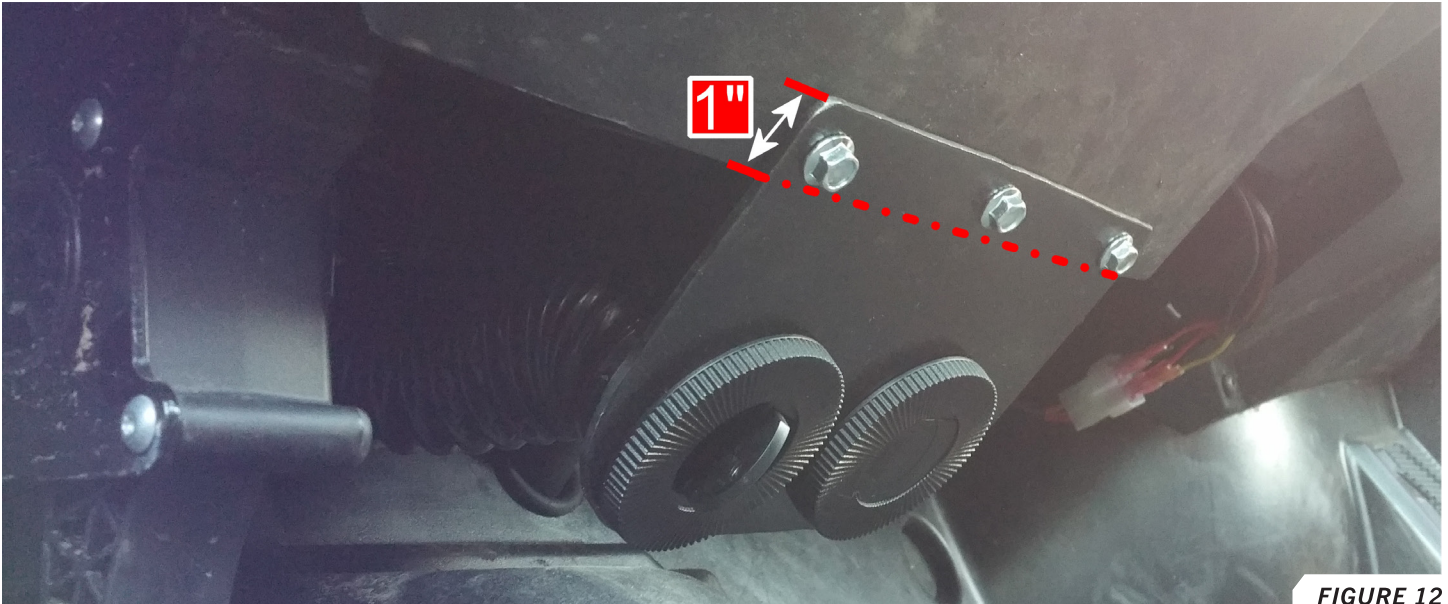
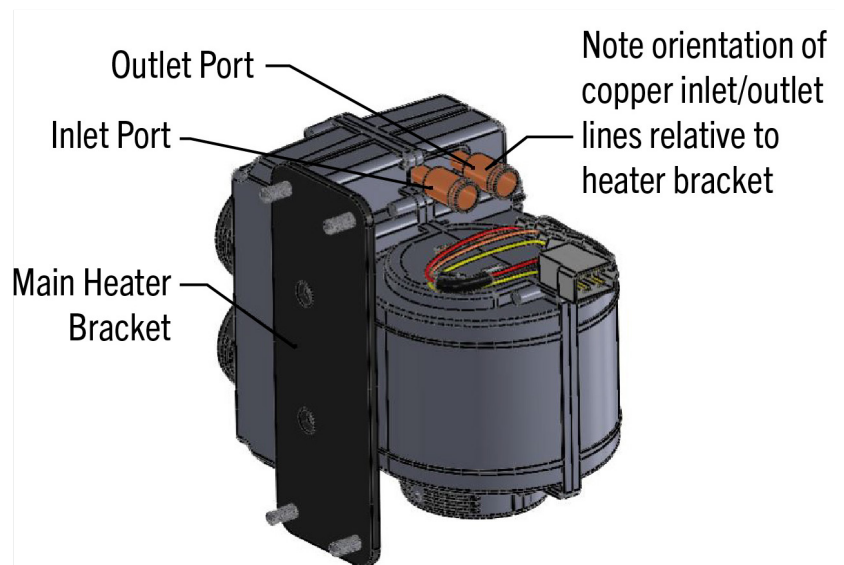

**FIGURE 12**

38. Mark the hole centers, remove the vent bracket and drill the hole locations using a 1/4" drill bit (not included). Do not install the vent bracket yet.

### HEATER ASSEMBLY

39. Set the top dash back into place and hang the two duct hose sections attached to the 2" vents down into the passenger footwell.
40. Mount the heater unit to the heater mount bracket using the included M6-1.0x14mm flat head cap screws. Note the orientation of the heater relative to the bracket as shown in *FIGURE 13*.



**FIGURE 13**

41. Attach the two 2" duct hoses coming from the 2" vents to the back two vent ports (nearest to the firewall). The driver side defrost hose is attached to the lower port and the passenger side defrost hose is attached to the upper port. Trim any excess hose and secure using the zip ties. **FIGURE 14**

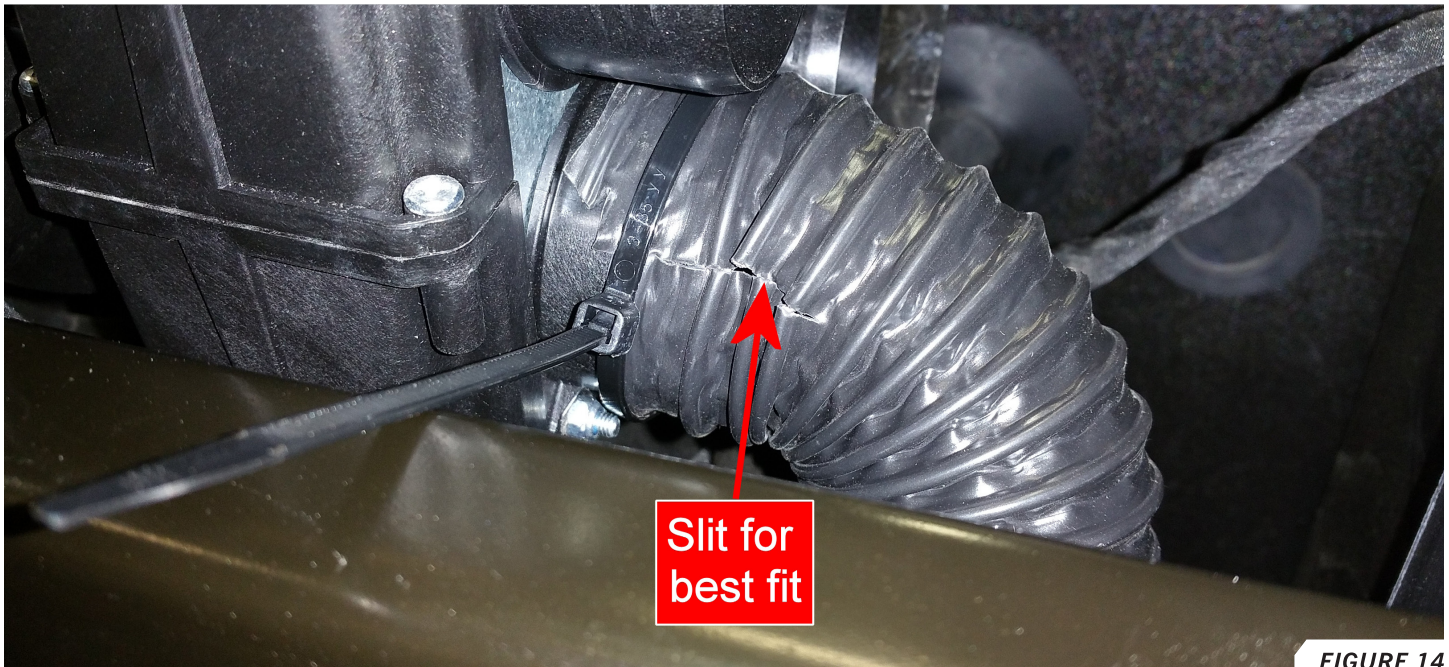

**FIGURE 14**

42. Cut the remaining 15" duct hose section into two 6" sections and discard the excess. Use the two 6" sections of duct hose and attach them in the same method to the remaining ports.
43. Position the heater unit assembly into the four holes drilled earlier with 4 ports pointed toward the driver side of the vehicle.  It will be necessary to pull back on the center console to fit the assembly into the holes.
44. Secure the assembly using the included 1/4" serrated flange nuts.
45. Connect the 4-Pin White Connector to the white terminal housing on the heater unit.

46. Attach the 5/8" radiator hose leading from the center tunnel rubber grommet to the inlet port on the heater unit as shown in *FIGURE 15*. Secure using a #10 hose clamp.
47. Attach the 5/8" radiator hose leading from the passenger side firewall rubber grommet hose (See *FIGURE 15*) to the outlet port on the heater unit (see *FIGURE 15*). Secure using a #10 hose clamp.
48. Attach the two 6" duct hoses to the back of the vents already installed in the vent bracket.
49. Install the vent bracket to the predrilled holes. Use the 1/4"x3/4" serrated flange bolts and nuts to secure the vent bracket to the center console as shown in *FIGURE 16*.

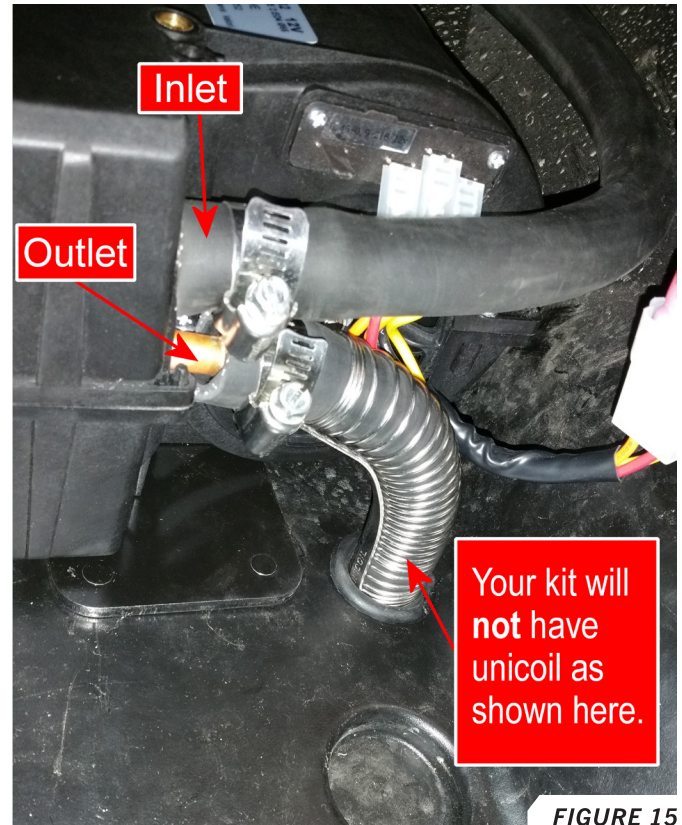

**FIGURE 15**



**FIGURE 16**

## RADIATOR HOSE INSTALLATION

50. From the passenger side wheel well, place a bucket under the lower radiator hose shown in *FIGURE 17*. Cut the radiator hose in the middle of the straight section that runs parallel to the radiator.

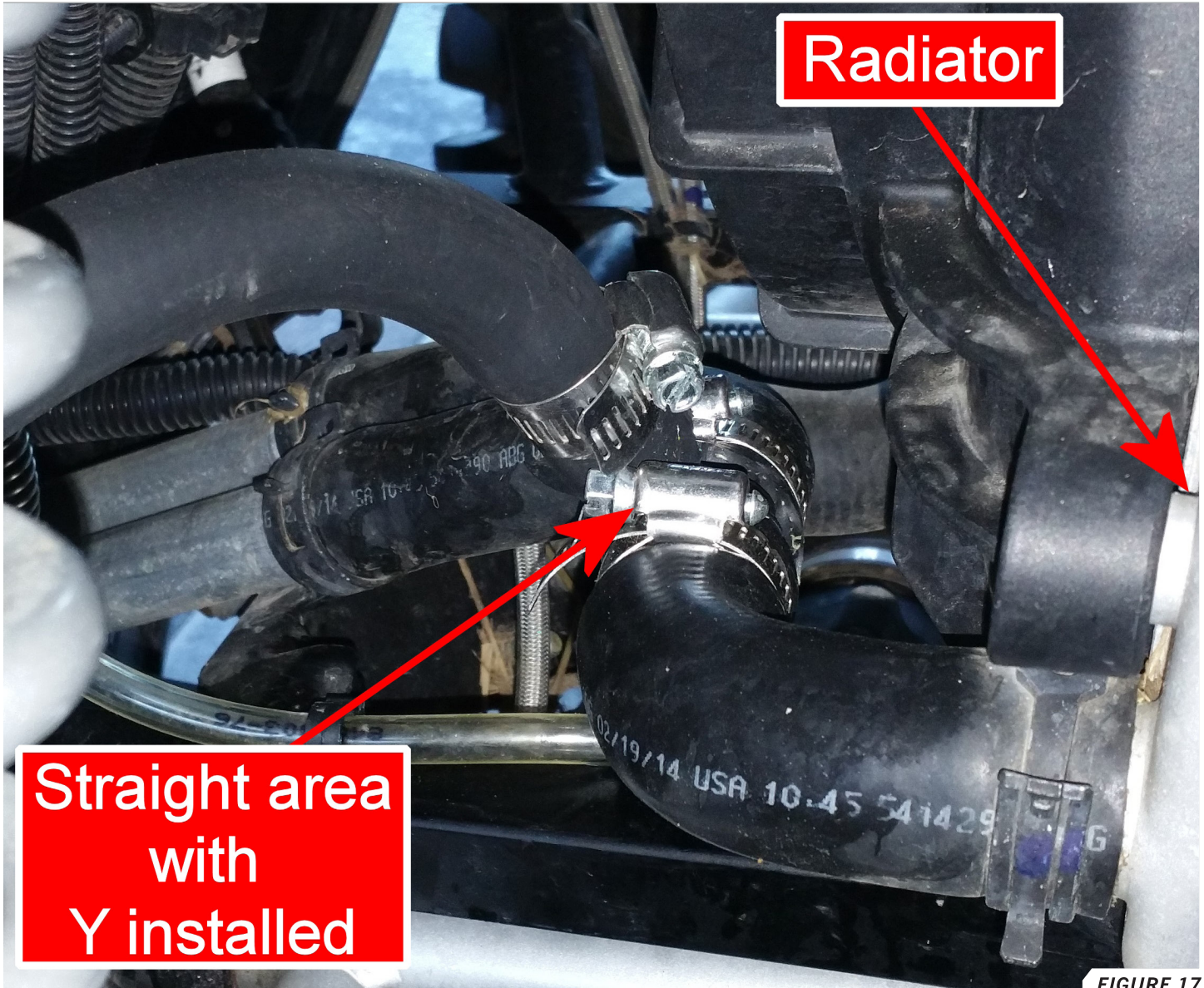

**FIGURE 17**

51. Insert the 1" aluminum Y with the  $\frac{5}{8}$ " branch facing the passenger wheel well. Use two of the larger #16 hose clamps to secure the Y as shown in *FIGURE 17*.
52. Route the  $\frac{5}{8}$ " radiator hose from the rubber grommet nearest the heater unit to the 1" aluminum Y. Cut the hose to length if necessary and secure with a #10 hose clamp. Take care not to kink the hose. *FIGURE 17*.

## THERMOSTAT BYPASS INSTALLATION

Ensure the vehicle's engine is cold before proceeding.

53. If applicable, tilt the bed of the vehicle to gain access to the engine.
54. Locate the thermostat as shown in *FIGURE 18*.

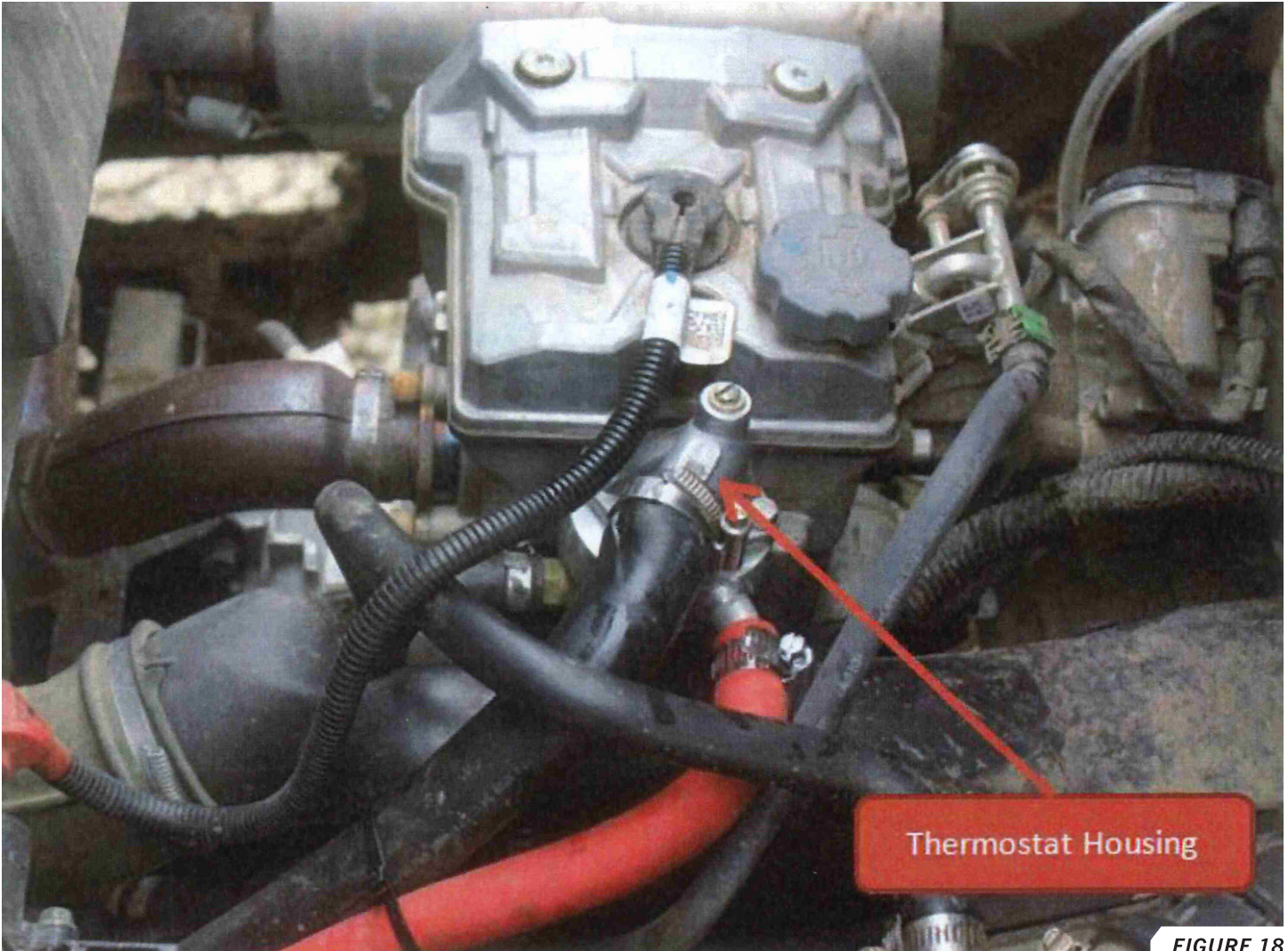

55. Remove the two bolts holding the thermostat housing to the engine block and set them aside.

56. Position the thermostat bypass valve so that 2" O-ring sits on top of the engine block and in the orientation shown in *FIGURE 19*.

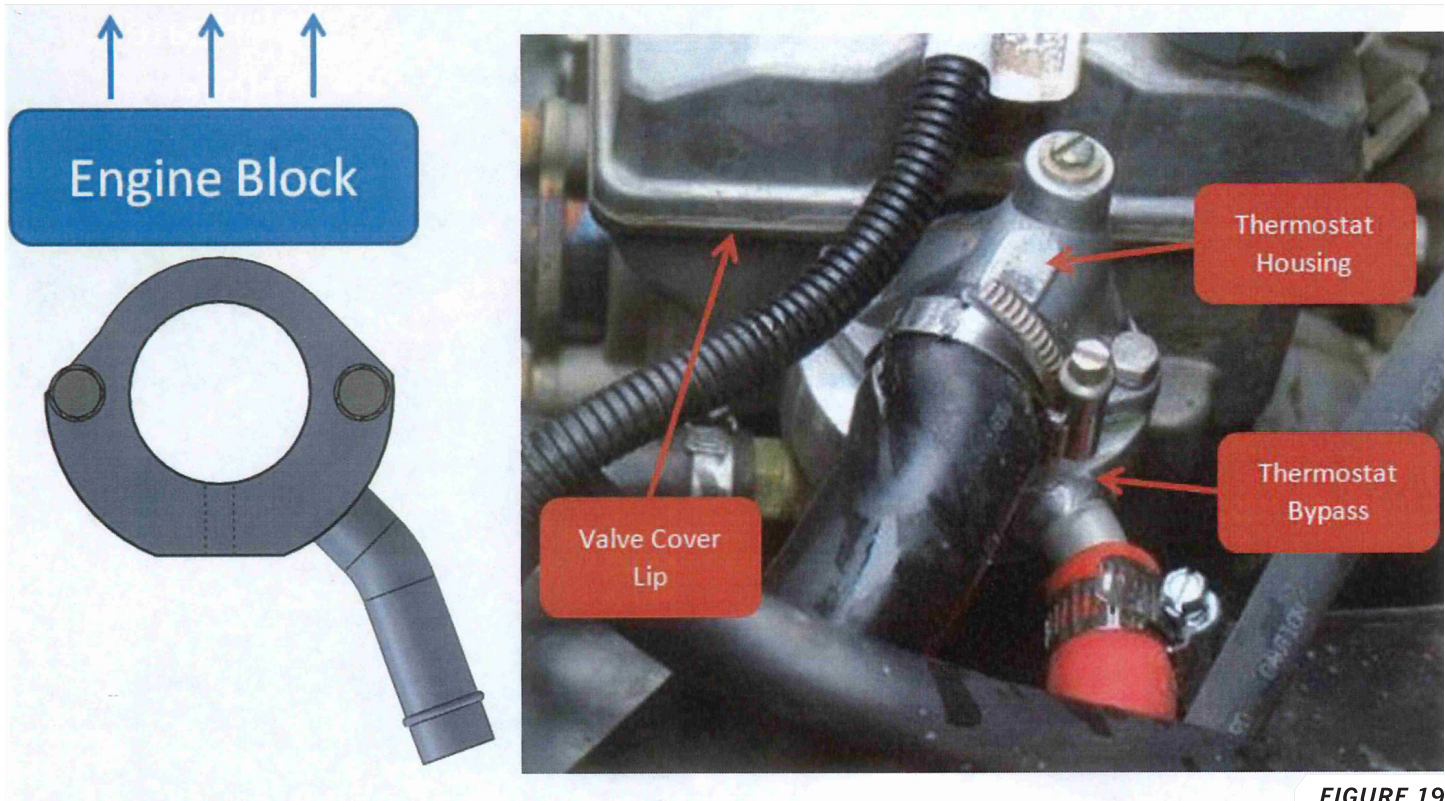

**FIGURE 19**

57. Position the thermostat inside the thermostat housing in the same orientation that it was removed. Loosely position the thermostat and thermostat housing over the thermostat bypass so that one of the mounting holes align.
58. Insert one of the two stainless steel M6 bolts and lock washers and hand tighten loosely.
59. Compress the 2" O-ring by pressing down on the thermostat housing. Once the thermostat housing is underneath the valve cover lip, rotate the thermostat housing until the second mounting hole aligns. Insert the remaining M6 bolt and lock washer and hand tighten both bolts. Use a wrench to tighten fully, not exceeding 8 ft-lbs of torque.

60. Attach the included  $\frac{5}{8}$ " heater hose (colored RED below for visibility) using the stainless steel hose clamp and route the house to the heater as shown in *FIGURE 20*. Attach the  $\frac{5}{8}$ " heater hose to the inlet hose of the heater unit.

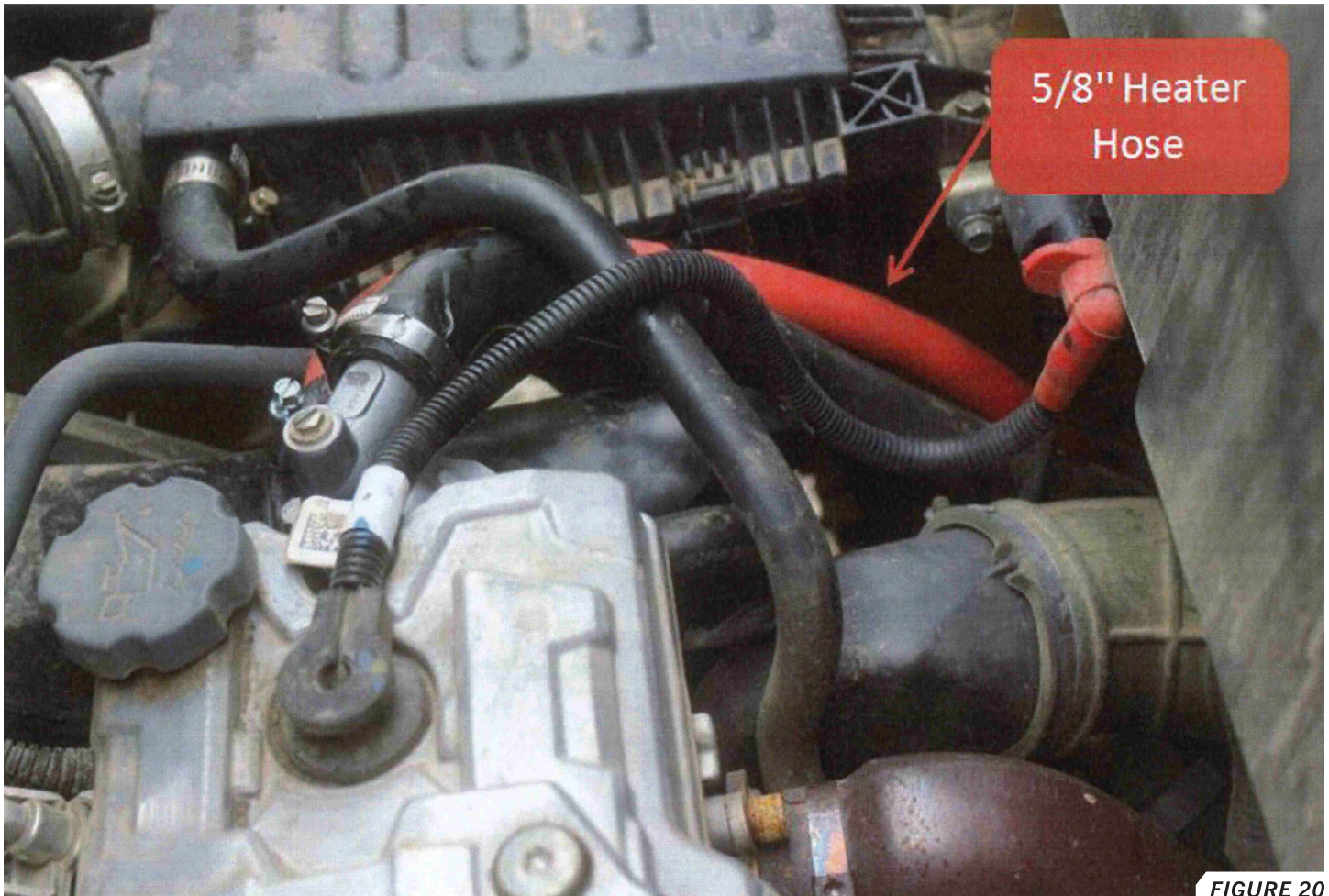

61. It may be necessary to grind a small amount of material off of the dump bed just above the thermostat housing to avoid hitting the 1" coolant lines.
62. Use the provided zip ties to secure the  $\frac{5}{8}$ " radiator hose to the vehicle.
63. Reassemble the engine components in reverse order.



### BLEEDING THE COOLANT SYSTEM

Read entire section before proceeding

 Some amount of air will have made its way into the coolant system. The following bleeding procedure must be performed to eliminate the air and obtain heat. The following procedure is most easily accomplished with the help of a partner.

64. Fill radiator with coolant until radiator is full.
65. Open the shut-off valve.
66. Close the radiator cap and drive the machine around until heat comes through the vents or the machine's engine temperature goes above 200°F. Turn off the machine and wait for it to cool down.
67. Open the radiator cap and add more coolant.
68. Repeat the steps in this section until consistent heat is coming out of the vents and machine temperature gauge stays under 200°F.
69. Verify that no leaks have occurred and that the radiator fluid level is per the manufacturer's specifications.

 Look at owner's manual for manufacturer-approved coolant

### FINISHING

70. Reinstall the radiator hood.
71. Reinstall the top dash.

**REPLACEMENT PARTS**



Replacement parts can be ordered from [motoalliance.com](http://motoalliance.com). Enter the associated SKU number into the search bar to find the product.

Item Description	SKU
2" Compressed Duct Hose	HT_2inch_Compressed
2" Vent	HT_2Louvre
FIRESTORM Heater Motor	RPL_HT_CU_Fan_and_Motor
3-Position Switch	HT-FanSwitch
5/8" Coolant Hose	HT_RadiatorHose_20
1" Aluminum Y	HT_AluminumY_1

Item Description	SKU
Thermostat Bypass Valve BP104	HT_BP104
Shut-Off Valve	HT_Plastic_Shut-off_Valve
Hole Saw Pilot Bit	HT_PilotBit
2" Hole Saw	HT_2_SAW
1¼" Hole Saw	HT_1.25_SAW

**Scan this QR code to see the full list of FIRESTORM replacement parts on [motoalliance.com](http://motoalliance.com)**



**Scan this QR code to get more tech help, watch troubleshooting videos, or submit a help form on [motoalliance.com](http://motoalliance.com)**



## Template #4 Center Tunnel Coolant Hose

- 1) Cut along template profile
- 2) Use masking tape to attach template to the Firewall just above the center tunnel
- 3) Mark hole center
- 4) Drill hole using 1 1/4" Hole Saw

Cut Along Template profile

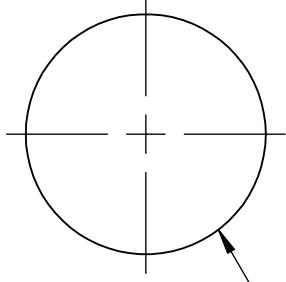

Hole Center for  
1 1/4" Hole Saw



# Template #3 Passenger Side Defrost Vent

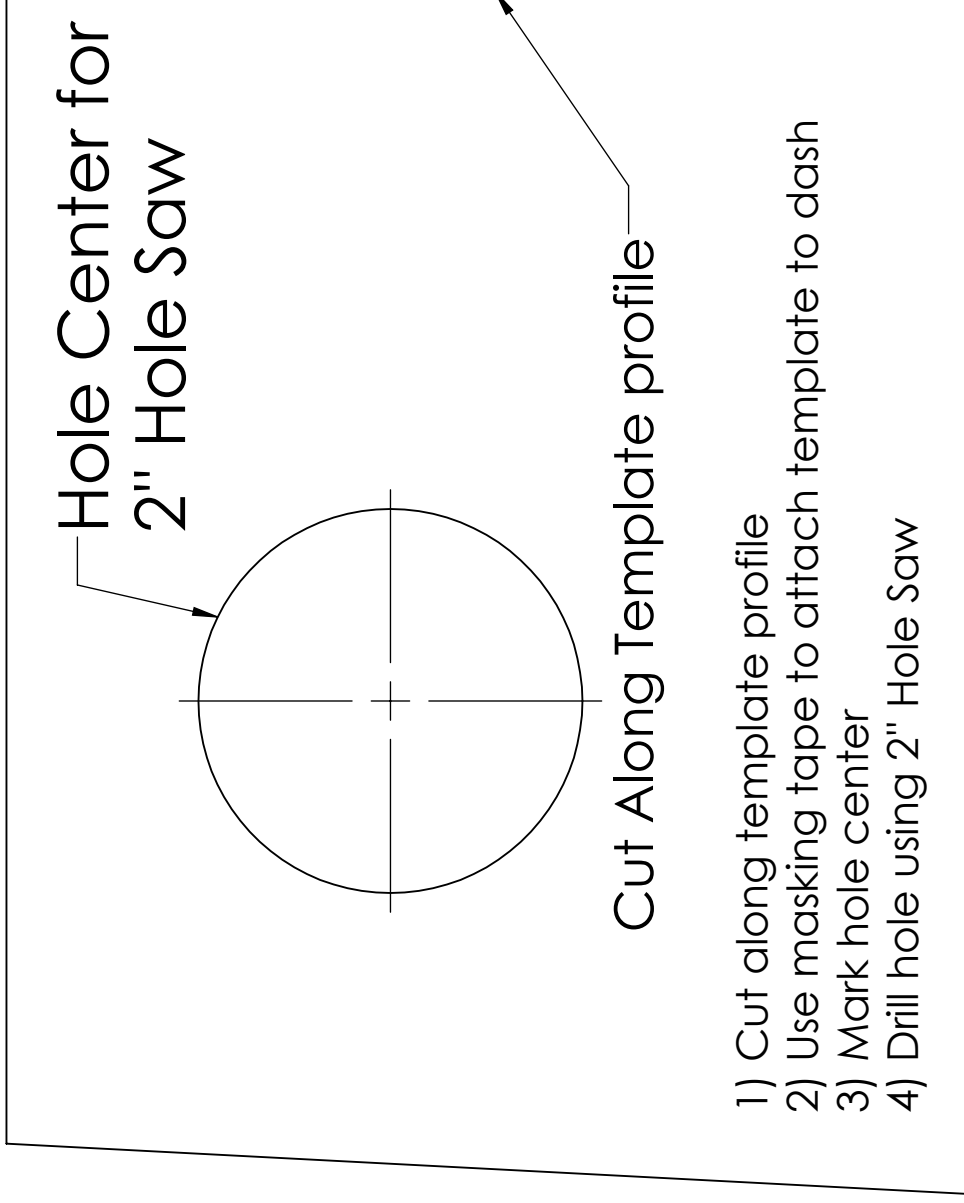



# Template #2 Driver Side Defrost Vent

Hole Center for  
2" Hole Saw

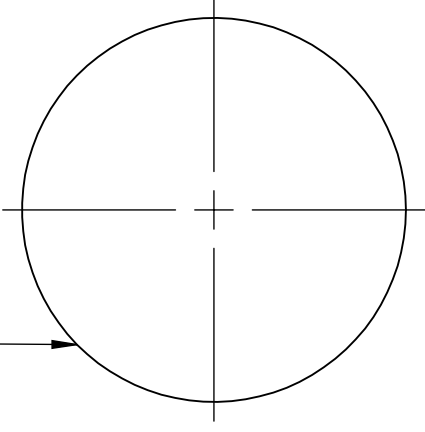

Cut Along Template profile

- 1) Cut along template profile
- 2) Use masking tape to attach template to dash
- 3) Mark hole center
- 4) Drill hole using 2" Hole Saw





# Template #1 Heater Mounting Template

- 1) Cut along template profile
- 2) Use masking tape to passenger side firewall
- 3) Mark hole center (5x)
- 4) Drill four small holes using a 5/16" drill bit
- 5) Drill large single hole using 1 1/4" Hole Saw

Align with recessed hole  
on Passenger Side firewall

Drill using 1 1/4" Hole Saw

Cut Along Template profile

